

LIGHT BEAM
- economic -

semiautomatic soldering station

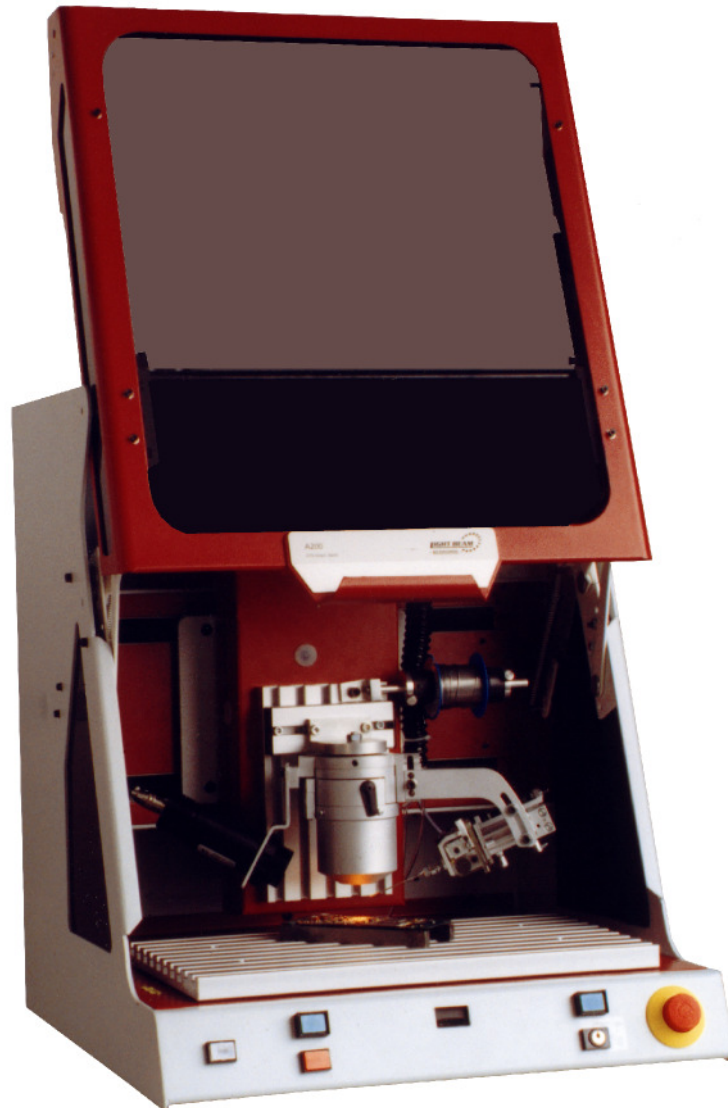

- ▶ *3-axes robot with PC-control*
- ▶ *programming system WinControl*
- ▶ *3 variants with moving range up to 395x300x140mm (xyz)*
- ▶ *closed area for the soldering process*
- ▶ *soldering system LightBeam with IR-Light*

Technical description of the components

single point soldering with infrared light

Soldering with focused, infrared light is a high precision technology applicable at single points in the production, final assembly, or repair of 3D MID components

The light source is a special halogen lamp with an integrated reflector and lens, which focus the emitted light at the soldering joint at the exact point where heat is needed. The advantages of soldering with infrared light are:

- precise heat application
- high process security
- low maintenance costs
- contact-free heat distribution

soldering system LightBeam

The main component of the unit is the LightBeam soldering system. With an input power of 250 W (150 W optionally), the ray reaches 10-15 W (8-10 W) soldering power at the focal point. The focal point diameter is 2-3 mm.

The radiation period and electrical power for the light source are numerically controlled and infinitely variable.

The feeder for the solder wire is very precise. It can handle solder wire with a diameter of 0.5 up to 1.5mm. It weights only 120g.

soldering station LightBeam economic

The triple-axes robot - which is available in 3 versions, A200, A300 and A400- positions the soldering system above the soldering joint.

The programming system Win-Control is the link to the user. Different positions for every solder joint can be controlled manually by mouse or keyboard, or optionally by a joystick.

All functions of the soldering process can be visualised and controlled via dialog boxes.

The solder joint of the current application is managed using the programming editor.

Coordinate plotting is done either by interactive teaching, direct input by keyboard, or by reading external data files. The parameters for the soldering process, such as light power, speed of solder wire feed, heating time, and timing of solder supply, can be adjusted individually for every solder joint of the application.

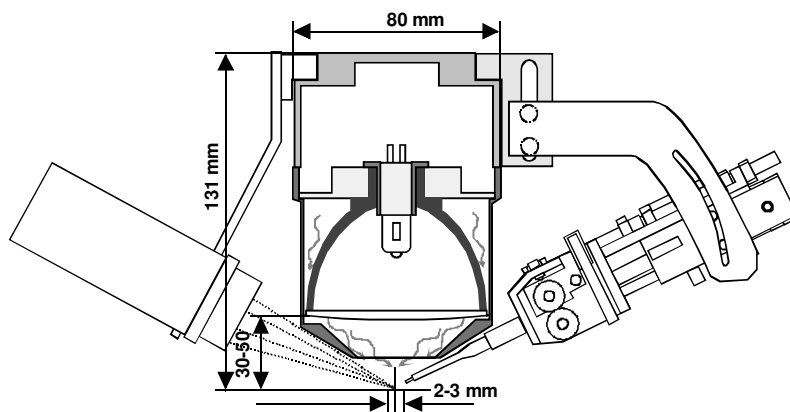

Options:

- ▶ temperature control (pyrometer)
- ▶ joystick for manual maneuvering
- ▶ Teach-in ccd-camera

Technical Data

Light-source:

power-input:	250 W / 150 W
power-output (focal point):	10 - 15 W / 8-10 W
diameter of focal point:	2,5 - 3,5 / 2,0-3,0 mm
focal length:	30 - 50 mm
wave length:	500 - 1500 nm
durability:	50 - 100 h

Solder supply:

drive:	12 V dc – motor with 1,7 W
Gearing:	1:166
Diameter (solder wire):	0,5 – 1,5 mm
feed:	2 – 24 mm/s
Adjustable parameters:	soldering-time, speed, wire-diameter

Positioning:

		A200	A300	A400
moving-range:	x-axis	200 mm	295 mm	395 mm
	y-axis	175 mm	200 mm	300 mm
	z-axis	90 mm	130 mm	140 mm
free passage width:		90 mm	115 mm	160 mm
size of table:	(x, y)	425 x 250 mm	500 x 250 mm	375 x 600mm
outer dimensions:	BxTxH	515x580x615mm	610x655x705mm	710x820x750mm

- ▶ Unlimited number of positions
- ▶ 5 parameters per solder joint
- ▶ world and tool coordinates